



Enhanced MPPT Control Strategy for Single Phase Grid Connected Power System

P.Manohar¹, Dr.A.Senthil Kumar², S.Vijipriya³, M.Kirthi Roshan⁴, R.Mahesh⁵, Mohamed Arshath⁶

Assistant Professor, Department of EEE, M.A.M. School of Engineering Tiruchirappalli, Tamil Nadu, India¹

Professor, Department of EEE, M.A.M. School of Engineering Tiruchirappalli,
Tamil Nadu, India²

Assistant Professor, Department of EEE, M.A.M. School of Engineering Tiruchirappalli, Tamil Nadu, India³

Student, Department of EEE, M.A.M.School of Engineering Tiruchirappalli, Tamil Nadu, India^{4,5,6}

Publication History: Received: 25.02.2026; Revised: 20.03.2026; Accepted: 25.03.2026; Published: 28.03.2026.

ABSTRACT: Photovoltaic (PV) systems have become one of the most promising renewable energy technologies for sustainable electricity generation. However, the efficiency and output power of PV systems are highly dependent on environmental conditions such as solar irradiance and temperature variations. These factors cause continuous changes in the operating point of the PV array, making it difficult to maintain operation at the maximum power point (MPP). To address this challenge, Maximum Power Point Tracking (MPPT) techniques are widely used to optimize energy extraction from PV systems.

This project presents the hardware implementation of an improved MPPT control system for a single-phase grid-connected photovoltaic system. The proposed system employs a DC–DC boost converter integrated with a Pulse Width Modulation (PWM)-based MPPT control algorithm. The controller dynamically adjusts the duty cycle of the boost converter to ensure that the PV array consistently operates at or near its maximum power point, even under rapidly changing environmental conditions. Compared with conventional MPPT methods, the improved algorithm enhances tracking accuracy, reduces steady-state oscillations around the maximum power point, and provides faster response to irradiance changes. The DC power generated by the PV array and conditioned through the boost converter is then converted into AC power using a single-phase inverter. The inverter synchronizes the output with the utility grid, allowing efficient power injection while maintaining stable operation. For system monitoring and performance analysis, real-time measurements of PV voltage and current are obtained through sensors and displayed on an LCD interface, providing users with immediate feedback on system performance.

Experimental results demonstrate that the proposed system achieves improved energy harvesting efficiency, faster MPPT response, and stable grid synchronization. Additionally, the design offers a cost-effective, reliable, and scalable solution suitable for residential and small-scale grid-connected photovoltaic applications. By improving power extraction and system stability, the proposed MPPT control approach contributes to enhanced utilization of solar energy and supports the broader integration of renewable energy sources into modern power grids.

KEYWORDS: Electric Vehicles, Solar Energy, Arduino Uno, EV Charging Infrastructure, Energy Efficiency

I. INTRODUCTION

The rapid growth of global energy demand, coupled with the depletion of fossil fuel resources and increasing environmental concerns, has accelerated the transition toward renewable energy sources. Traditional energy generation methods based on coal, oil, and natural gas contribute significantly to greenhouse gas emissions, climate change, and environmental degradation. As a result, there has been a global effort to develop clean, sustainable, and environmentally friendly energy solutions.

Renewable energy sources such as solar, wind, hydroelectric, geothermal, and biomass offer promising alternatives to conventional fossil fuels. Among these sources, solar energy has gained significant attention due to its abundance, availability, and minimal environmental impact. The sun provides an enormous amount of energy to the Earth, far



exceeding global energy consumption. Harnessing this energy effectively can significantly contribute to meeting future energy demands while reducing environmental harm.

Solar energy can be utilized through various technologies, including solar thermal systems and photovoltaic (PV) systems. Photovoltaic systems directly convert sunlight into electrical energy using semiconductor materials. Over the past few decades, PV technology has experienced significant improvements in efficiency, cost reduction, and reliability, making it one of the fastest-growing renewable energy technologies worldwide.

The integration of photovoltaic systems into electrical grids has become increasingly common in both residential and commercial applications. Grid-connected PV systems allow excess energy generated by solar panels to be fed into the utility grid, improving overall energy efficiency and reducing reliance on conventional power plants. However, the performance of PV systems is highly dependent on environmental factors such as solar irradiance and temperature, which vary throughout the day and across different seasons. These variations significantly affect the power output of photovoltaic modules.

To maximize the efficiency of PV systems under changing environmental conditions, advanced power electronic converters and control algorithms are required. One of the most important techniques used in PV systems is Maximum Power Point Tracking (MPPT), which ensures that the photovoltaic array operates at its optimal power point at all times

Objectives

The specific objectives of the system are as follows:

1. Minimization of Steady-State Oscillations.
2. Suppression of Second-Order Harmonic Ripple.
3. Acceleration of Dynamic Response.
4. Mitigation of Partial Shading Effects.
5. Enhancement of DC-Link Voltage Stability.
6. Compliance with Grid Codes (THD and Power Factor).

II. LITERATURE SURVEY

2.1. P. S. Reddy, K. Srinivas (2022)

This paper presents a hardware implementation of an improved MPPT algorithm for single-phase grid-connected PV systems. The PV array is connected to a boost converter, and a PWM-based control algorithm continuously tracks the maximum power point using real-time voltage and current measurements. The DC output is converted to AC through a single-phase inverter and synchronized with the grid. System parameters are displayed on an LCD module, providing real-time monitoring of PV voltage, current, and power. The results show enhanced energy yield, reduced voltage/current oscillations, and fast response to changing irradiance conditions. The paper highlights practical implementation challenges and demonstrates the system's scalability for residential and small-scale PV installations.

2.2. A. K. Yadav, R. K. Tripathi Year (2020)

This paper reviews various MPPT techniques used in photovoltaic systems, including Perturb and Observe (P&O), Incremental Conductance (IncCond), and hybrid algorithms. It compares their performance under varying solar irradiance and temperature conditions. The study highlights the advantages of advanced MPPT algorithms in reducing steady-state oscillations and improving dynamic response. Hardware implementations using PWM-based DC-DC converters, such as boost converters, are discussed. The paper emphasizes real-time voltage and current measurement requirements for accurate MPPT operation. It also reviews grid-connected single-phase inverters for PV integration, including their role in stable AC power delivery. The authors conclude that improved MPPT methods provide better energy yield, reduced conversion losses, and scalable solutions for small and medium PV systems. Simulation and experimental validations of various MPPT strategies are also summarized.

2.3.S. Patil, M. Joshi Year(2019)

This work presents the design and hardware implementation of a single-phase grid-connected PV system with MPPT control. The PV array output is interfaced with a boost converter, controlled using a PWM-based MPPT algorithm. Real-time voltage and current measurements are used to track the maximum power point efficiently. A single-phase inverter converts the DC output to AC for grid synchronization. LCD display modules provide monitoring of system parameters such as PV voltage, current, and power. The paper demonstrates improved system efficiency, faster tracking



response, and reduced oscillations compared to conventional P&O algorithms. Experimental results validate the proposed system for residential-scale PV applications, emphasizing cost-effectiveness and practical feasibility.

2.4. K. Sharma, R A. Gupta Year (2021)

This paper focuses on a hardware-based Incremental Conductance (IncCond) MPPT technique for single-phase grid-connected PV systems. The PV array is interfaced with a DC-DC boost converter and a PWM-controlled inverter. Voltage and current sensors continuously measure PV output, which is displayed on an LCD module for real-time monitoring. The system dynamically adjusts the duty cycle of the boost converter to maintain maximum power extraction under changing irradiance and temperature. Results show that IncCond MPPT provides faster response and higher energy yield compared to classical P&O methods. Grid synchronization is maintained, ensuring stable AC delivery and reducing power fluctuations. The study highlights practical challenges in hardware implementation and demonstrates scalability for small-scale PV system.

2.5 Existing system

(MPPT) techniques to extract energy from solar panels. In many earlier PV systems, the control methods used to track the maximum power point were relatively simple and often lacked Traditional photovoltaic (PV) systems typically rely on conventional Maximum Power Point Tracking the ability to respond effectively to rapid changes in environmental conditions such as solar irradiance and temperature.

Most existing PV systems use basic MPPT algorithms such as the Perturb and Observe (P&O) method or the Hill Climbing method. Although these techniques are widely used due to their simplicity and ease of implementation, they suffer from several limitations. One of the main disadvantages is the oscillation around the maximum power point during steady-state operation. These oscillations lead to unnecessary power losses and reduce the overall efficiency of the PV system. Another limitation of the existing system is the slow response of conventional MPPT algorithms when environmental conditions change rapidly. For example, when solar irradiance fluctuates due to cloud movement, the algorithm may take time to adjust the operating point of the PV array. During this period, the system operates away from the optimal power point, resulting in reduced energy extraction.

In addition, some traditional PV systems use simple DC-DC converters without advanced control strategies. This may lead to poor voltage regulation and inefficient power conversion. The absence of efficient monitoring systems in some earlier designs also limits the ability to track system performance in real time. Grid-connected PV systems in earlier implementations also faced challenges in maintaining stable synchronization with the utility grid. Improper synchronization can cause power quality issues and reduce the reliability of the system. Overall, while conventional PV systems with standard MPPT techniques provide basic functionality, their performance is often limited by slow tracking speed, power oscillations, and lower efficiency under dynamic environmental conditions. These limitations highlight the need for improved MPPT control methods to enhance the performance and reliability of photovoltaic systems.

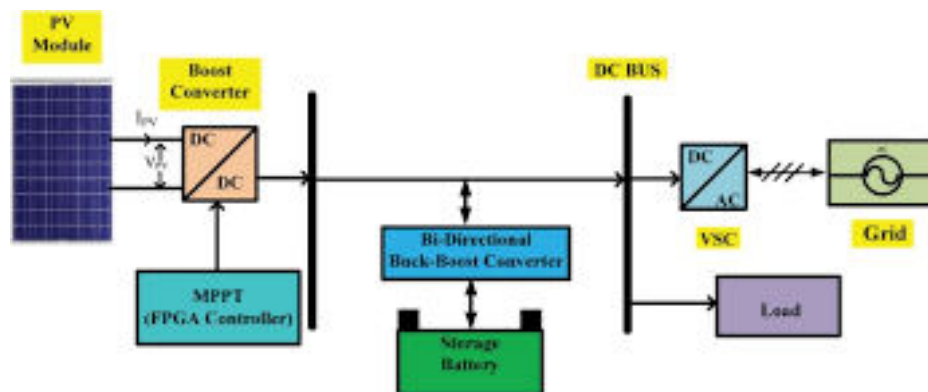

Fig 2.6 Architecture Diagram

FPGA (Field-Programmable Gate Array) architecture consists of a 2D matrix of configurable logic blocks (CLBs), programmable interconnects, and I/O blocks, allowing for post-manufacturing reconfiguration to implement custom digital circuits. Key components include Look-Up Tables (LUTs) for logic, flip-flops for storage, block RAM for memory, and DSP slices for arithmetic

Schematic Diagram:

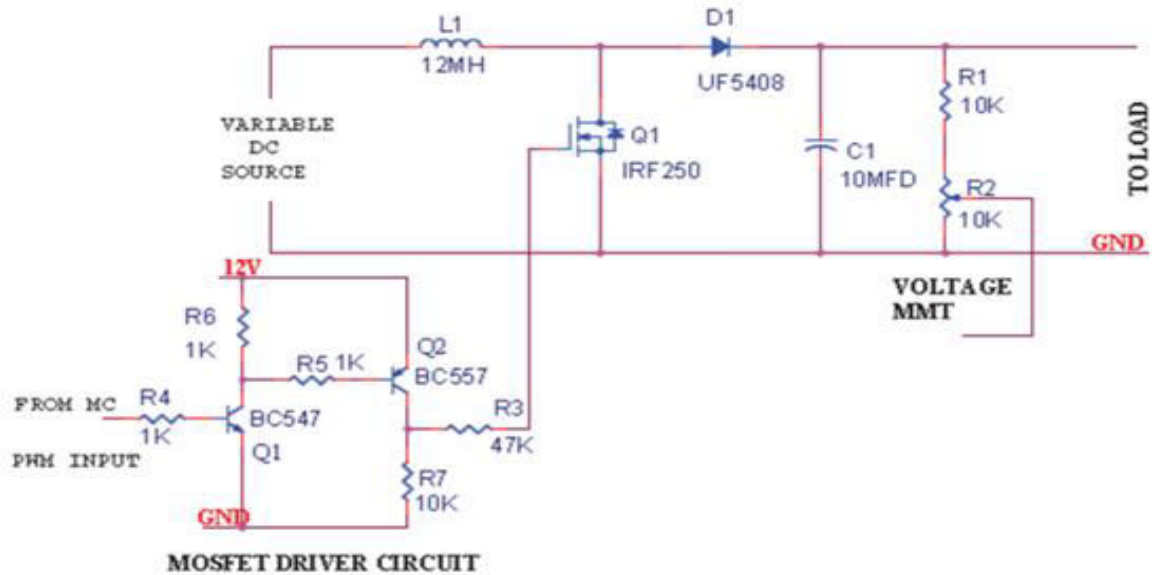

Fig2.7 Proposed circuit diagram of the project

III. HARDWAREDESCRIPTION

3.1.ARDUINO UNO

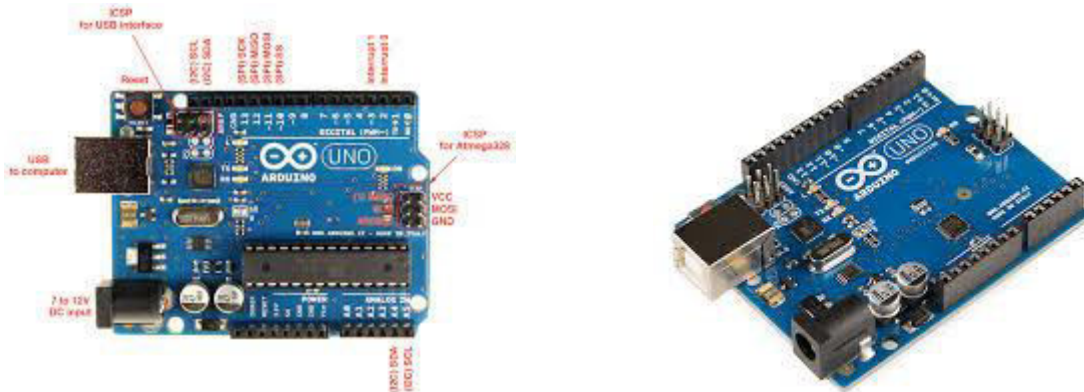

Fig 3.1 Pin Details of Aurdino Nano

Arduino/Genuino Uno is a microcontroller board based on the ATmega328P . It has 14 digital input/output pins (of which 6 can be used as PWM outputs), 6 analog inputs, a 16 MHz quartz crystal, a USB connection, a power jack, an ICSP header and a reset button. It contains everything needed to support the microcontroller; simply connect it to a computer with a USB cable or power it with a AC-to-DC adapter or battery to get started.. You can tinker with your UNO without worrying too much about doing something wrong, worst case scenario you can replace the chip for a few dollars and start over again.

3.1. POWER SUPPLY

A power supply (sometimes known as a power supply unit or PSU) is a device or system that supplies electrical or other types of energy to an output load or group of loads. The term is most commonly applied to electrical energy supplies, less often to mechanical ones, and rarely to others.This circuit is a small +5V power supply, which is useful

when experimenting with digital electronics. Small inexpensive wall transformer with variable output voltage are available from any electronics shop and supermarket. Those transformers are easily available, but usually their voltage regulation is very poor, which makes them not very usable for digital circuit experimenter unless a better regulation can be achieved in some way. The following circuit is the answer to the problem.

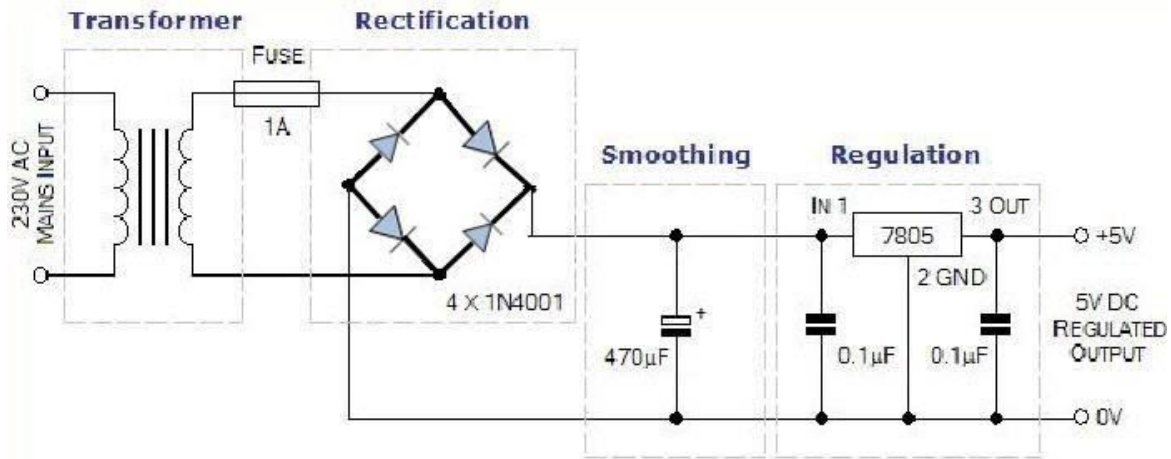

Fig 3.2 Power Supply

3.3 LCD (LIQUID CRYSTAL DISPLAY)

LCD (Liquid Crystal Display) screen is an electronic display module and findawiderangeofapplications. A16x2 LCDdisplayis verybasic moduleand is very commonly used in various devices and circuits.A 16x2 LCD means it can display 16 characters per line and there are 2 such lines. In this LCD each character is displayed in 5x7 pixel matrix. This LCD has two registers, namely, Command and Data. The command register stores the command instructions given to the LCD, The data register stores the data to be displayed on the LCD The data is the ASCII value of the character to be displayed on the LCD.Liquid crystal displays are used for display of numeric and alphanumeric character in dot matrix and segmental displays. The two liquid crystal materials which are commonly used in display technology are nematic and cholesteric whose schematic arrangement of molecules is shown in fig. The most popular liquid crystal structure is the Nematic Liquid Crystal (NLC). In this all the molecules align themselves approximately parallel to a unique axis (director), while retaining the complete translational freedom. The liquid is normally transparent, but if subjected to a strong electric field, disruption of the well ordered crystal structure takes place causing the liquid to polarize and turn opaque.

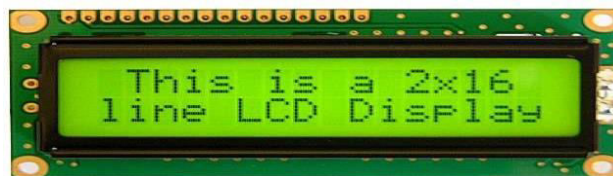

Fig 3.3 LCD Display

3.4 PV PANEL

A photovoltaic (PV) panel, commonly known as a solar panel, is a device that converts sunlight directly into electricity using the principle of the photovoltaic effect PV panels are widely used in renewable energy systems to generate clean and sustainable electrical power. As the demand for alternative energy sources increases due to environmental concerns and the depletion of fossil fuels, photovoltaic technology has gained significant importance across the world. PV panels play a crucial role in solar power generation systems used in residential buildings, industries, agricultural fields, and remote areas where conventional electricity supply is limited or unavailable.



The system was developed using a photovoltaic panel, a DC–DC boost converter, an improved MPPT control algorithm, and a single-phase inverter. The MPPT controller continuously monitors the PV voltage and current and adjusts the duty cycle of the boost converter to extract maximum power from the PV panel. The boost converter increases the PV output voltage to a suitable level for the inverter stage. The single-phase inverter then converts the DC power into AC power and synchronizes it with the grid for efficient power delivery.

Experimental results show that the proposed system successfully tracks the maximum power point and improves the overall efficiency of the PV system. The improved MPPT algorithm reduces steady-state oscillations and provides faster response to changes in solar conditions compared to conventional methods. The LCD display allows real-time monitoring of system parameters such as voltage and current, which improves system reliability and performance analysis. Overall, the proposed system demonstrates reliable operation, efficient power conversion, and stable grid synchronization. The implementation of an improved MPPT control technique enhances solar energy utilization and makes the system suitable for residential and small-scale grid-connected photovoltaic applications. This project contributes to the development of efficient and sustainable renewable energy systems.

V. FUTURE SCOPE

- └ Integration of advanced Maximum Power Point Tracking (MPPT) techniques to further improve solar energy harvesting efficiency under varying weather conditions.
- └ Development of dynamic wireless charging systems, enabling electric vehicles to charge while in motion on specially designed roads.
- └ Improvement in coil design and alignment mechanisms to enhance power transfer efficiency and reduce energy losses.
- └ Incorporation of Artificial Intelligence (AI) and machine learning algorithms for smart energy management, load prediction, and adaptive charging control.
- └ Expansion of the system with IoT-based monitoring and control, allowing real-time tracking, remote access, and data analytics.
- └ Use of high-efficiency power electronics components to minimize losses and increase overall system performance.
- └ Integration with smart grid technology to enable bidirectional power flow and better energy distribution.
- └ Development of compact and cost-effective designs to make the system more affordable and suitable for widespread adoption.
- └ Implementation of multi-vehicle wireless charging stations to support simultaneous charging of multiple EVs.
- └ Enhancement of energy storage systems, such as advanced batteries or supercapacitors, to ensure continuous operation during low solar availability.
- └ Adoption of standardization protocols for wireless charging to ensure compatibility across different EV models and manufacturers.

REFERENCES

1. T. Esum and P. L. Chapman, "Comparison of Photovoltaic Array Maximum Power Point Tracking Techniques," *IEEE Transactions on Energy Conversion*, vol. 22, no. 2, pp. 439–449, June 2007.
2. N. Femia, G. Petrone, G. Spagnuolo, and M. Vitelli, "Optimization of Perturb and Observe Maximum Power Point Tracking Method," *IEEE Transactions on Power Electronics*, vol. 20, no. 4, pp. 963–973, July 2005.
3. H. Patel and V. Agarwal, "Maximum Power Point Tracking Scheme for PV Systems Operating Under Partially Shaded Conditions," *IEEE Transactions on Industrial Electronics*, vol. 55, no. 4, pp. 1689–1698, April 2008.
4. M. A. Elgendy, B. Zahawi, and D. J. Atkinson, "Assessment of Perturb and Observe MPPT Algorithm Implementation Techniques," *IEEE Transactions on Sustainable Energy*, vol. 3, no. 1, pp. 21–31, January 2012.
5. S. Jain and V. Agarwal, "A Single-Stage Grid Connected Inverter Topology for Solar PV Systems with Maximum Power Point Tracking," *IEEE Transactions on Power Electronics*, vol. 22, no. 5, pp. 1928–1940, September 2007.
6. D. P. Hohm and M. E. Ropp, "Comparative Study of Maximum Power Point Tracking Algorithms Using an Experimental, Programmable, Maximum Power Point Tracking Test Bed," *Proceedings of the IEEE Photovoltaic Specialists Conference*, pp. 1699–1702, 2000.
7. J. A. Gow and C. D. Manning, "Development of a Photovoltaic Array Model for Use in Power-Electronics Simulation Studies," *IEE Proceedings – Electric Power Applications*, vol. 146, no. 2, pp. 193–200, March 1999.
8. C. Nagarajan and M. Madheswaran - 'Stability Analysis of Series Parallel Resonant Converter with Fuzzy Logic Controller Using State Space Techniques'- Taylor & Francis, *Electric Power Components and Systems*, Vol.39 (8), pp.780-793, May 2011. DOI: 10.1080/15325008.2010.541746



9. C.Nagarajan and M.Madheswaran - 'Experimental verification and stability state space analysis of CLL-T Series Parallel Resonant Converter' - Journal of Electrical Engineering, Vol.63 (6), pp.365-372, Dec.2012. DOI: 10.2478/v10187-012-0054-2
10. C.Nagarajan and M.Madheswaran - 'Performance Analysis of LCL-T Resonant Converter with Fuzzy/PID Using State Space Analysis'- Springer, Electrical Engineering, Vol.93 (3), pp.167-178, September 2011. DOI 10.1007/s00202-011-0203-9
11. S.Tamilselvi, R.Prakash, C.Nagarajan, "Solar System Integrated Smart Grid Utilizing Hybrid Coot-Genetic Algorithm Optimized ANN Controller" Iranian Journal Of Science And Technology-Transactions Of Electrical Engineering, DOI10.1007/s40998-025-00917-z,2025
12. S.Tamilselvi, R.Prakash, C.Nagarajan, " Adaptive sliding mode control of multilevel grid-connected inverters using reinforcement learning for enhanced LVRT performance" Electric Power Systems Research 253 (2026) 112428, doi.org/10.1016/j.epsr.2025.112428
13. S.Thirunavukkarasu, C. Nagarajan, 2024, "Performance Investigation on OCF and SCF study in BLDC machine using FTANN Controller," Journal of Electrical Engineering And Technology, Volume 20, pages 2675–2688, (2025), doi.org/10.1007/s42835-024-02126-w
14. C. Nagarajan, M.Madheswaran and D.Ramasubramanian- 'Development of DSP based Robust Control Method for General Resonant Converter Topologies using Transfer Function Model'- *Acta Electrotechnica et Informatica Journal* , Vol.13 (2), pp.18-31, April-June.2013, DOI: 10.2478/aeei-2013-0025.
15. C.Nagarajan and M.Madheswaran - 'DSP Based Fuzzy Controller for Series Parallel Resonant converter'- *Springer, Frontiers of Electrical and Electronic Engineering*, Vol. 7(4), pp. 438-446, Dec.12. DOI 10.1007/s11460-012-0212-0.
16. C.Nagarajan and M.Madheswaran - 'Experimental Study and steady state stability analysis of CLL-T Series Parallel Resonant Converter with Fuzzy controller using State Space Analysis'- *Iranian Journal of Electrical & Electronic Engineering*, Vol.8 (3), pp.259-267, September 2012.
17. C.Nagarajan and M.Madheswaran, "Analysis and Simulation of LCL Series Resonant Full Bridge Converter Using PWM Technique with Load Independent Operation" has been presented in ICTES'08, a IEEE / IET International Conference organized by M.G.R.University, Chennai. Vol.no.1, pp.190-195, Dec.2007
18. Suganthi Mullainathan, Ramesh Natarajan, "An SPSS and CNN modelling based quality assessment using ceramic materials and membrane filtration techniques", *Revista Materia (Rio J.)* Vol. 30, 2025, DOI: <https://doi.org/10.1590/1517-7076-RMAT-2024-0721>
19. M Suganthi, N Ramesh, "Treatment of water using natural zeolite as membrane filter", *Journal of Environmental Protection and Ecology*, Volume 23, Issue 2, pp: 520-530,2022
- 20.
21. R. Faranda and S. Leva, "Energy Comparison of MPPT Techniques for PV Systems," *WSEAS Transactions on Power Systems*, vol. 3, no. 6, pp. 446–455, 2008.
22. S. B. Kjaer, J. K. Pedersen, and F. Blaabjerg, "A Review of Single-Phase Grid-Connected Inverters for Photovoltaic Modules," *IEEE Transactions on Industry Applications*, vol. 41, no. 5, pp. 1292–1306, September 2005.
23. G. Walker, "Evaluating MPPT Converter Topologies Using a MATLAB PV Model," *Journal of Electrical & Electronics Engineering*, vol. 21, no. 1, pp. 49–56, 2001.
24. **Kiran, A., Rubini, P., & Kumar, S. S. (2025).** Comprehensive review of privacy, utility and fairness offered by synthetic data. *IEEE Access*.
25. **Gopinathan, V. R. (2024).** Real-Time Financial Risk Intelligence Using Secure-by-Design AI in SAP-Enabled Cloud Digital Banking. *International Journal of Computer Technology and Electronics Communication*, 7(6), 9837-9845.
26. **Udayakumar, R., Elankavi, R., Vimal, R., & Sugumar, R. (2023).** Improved Particle Swarm Optimization with Deep Learning-Based Municipal Solid Waste Management in Smart Cities. *Environmental & Social Management Journal*, 17(4).
27. **Anand, L. (2023).** An Intelligent AI and ML-Driven Cloud Security Framework for Financial Workflows and Wastewater Analytics. *International Journal of Humanities and Information Technology*, 5(02), 87-94.
28. **Soundappan, S. J. (2020).** Big Data Analytics in Healthcare: Applications for Pandemic Forecasting. *International Journal of Advanced Research in Computer Science & Technology*, 3(1), 2248-2253.
29. **Rajasekar, M. (2024).** Real-Time Predictive DevOps Intelligence for Risk-Aware Digital Business Processes in Cloud and SAP Ecosystems. *International Journal of Advanced Research in Computer Science & Technology*, 7(4), 10713-10718.
30. **Poornima, G., & Anand, L. (2024, May).** Novel AI Multimodal Approach for Combating Against Pulmonary Carcinoma. In **2024 5th International Conference for Emerging Technology (INCET) (pp. 1-6)**. IEEE.
31. **Prabha, P. S., & Rengarajan, A. (2025).** Adaptive Cloud Resource Allocation Using Attention-Driven Deep Reinforcement Learning. *Engineering, Technology & Applied Science Research*, 15(6), 29334-29340.



32. Jagadeesh, S., & Sugumar, R. (2017). A Comparative study on Artificial Bee Colony with modified ABC algorithm. *European Journal of Applied Sciences*, 9(5), 243-248.
33. Varma, K. K., & Anand, L. (2025, March). Deep Learning Driven Proactive Auto Scaler for High-Quality Cloud Services. In *International Conference on Computing and Communication Systems for Industrial Applications* (pp. 329-338). Singapore: Springer Nature Singapore.
34. Kumar, S. A., & Anand, L. (2025). A Novel EEG-Based Deep Learning Framework for Enhancing Communication in Locked-In Syndrome Using P300 Speller and Attention Mechanisms. *KSII TRANSACTIONS ON INTERNET AND INFORMATION SYSTEMS*, 19(11), 3841-3855.
35. Poornima, G., & Anand, L. (2025). Medical image fusion model using CT and MRI images based on dual scale weighted fusion based residual attention network with encoder-decoder architecture. *Biomedical Signal Processing and Control*, 108, 107932.
36. Archana, R., & Anand, L. (2025). Residual u-net with Self-Attention based deep convolutional adaptive capsule network for liver cancer segmentation and classification. *Biomedical Signal Processing and Control*, 105, 107665.
- Kumar, S. A., & Anand, L. (2025). A Novel EEG-Based Deep Learning Framework for Enhancing Communication in Locked-In Syndrome Using P300 Speller and Attention Mechanisms. *KSII Transactions on Internet and Information Systems*, 19(11), 3841-3855.
37. Rengarajan, A. (2025). Cloud-Based AI-Driven Threat Detection Framework for Smart Grid Cybersecurity. *International Journal of Future Innovative Science and Technology*, 8(6), 16065.
38. Murugeswari, B., Sudharson, K., Panimalar, S. P., Shanmugapriya, M., & Abinaya, M. (2020). SAFE-Secure Authentication in Federated Environment using CEG Key code.
39. Raj A. A., & Sugumar, R. (2023). Early Detection of COVID-19 with Impact on Cardiovascular Complications using CNN Utilising Pre-Processed Chest X-Ray Images. *2023 International Conference on Applied Intelligence and Sustainable Computing (ICAISC)*, IEEE.
40. Jagadeesh, S., & Sugumar, R. (2017). A Comparative study on Artificial Bee Colony with modified ABC algorithm. *European Journal of Applied Sciences*, 9(5), 243-248.
41. Selvi, G. V., Anbarasan, A. B., Murthy, B. A., & Prabavathy, S. (2023). An Application Oriented Integrated Unequal Clustering Algorithm for Wireless Sensor Network. In *Underwater Vehicle Control and Communication Systems Based on Machine Learning Techniques* (pp. 140-154). CRC Press.
42. Sruthi, R. S., Ananya, S., & Murugeswari, B. (2010). Web Based Virtual Control System Laboratory and On-Line Temperature Control of Electrophoresis Equipment using LabVIEW. *International Journal of Computer Applications*, 975, 8887.
43. Vimal Raja, G. (2021). Mining Customer Sentiments from Financial Feedback and Reviews using Data Mining Algorithms. *International Journal of Innovative Research in Computer and Communication Engineering*, 9(12), 14705-14710.
44. MATHEW, A. R. (2025). Neurosecurity and Brain-Computer Interfaces.
45. Soundappan, S. J. (2024). AI-Driven Customer Intelligence in Enterprise Lakehouse Systems Sentiment Mining Governance-Aware Analytics and Real-Time Data Synchronization. *International Journal of Advanced Engineering Science and Information Technology (IJAESIT)*, 7(5), 14905.
46. Mathew, A. (2025). Human-AI Collaboration in Security Operations: Measuring Alert Trust, Automation Bias, and Analyst Upskilling in AI-Augmented SOC Environments. *International Journal of Computer Technology and Electronics Communication*, 8(5), 11375-11380.
47. Soundappan, S. J. (2022). AI-Based Fault Detection and Isolation for Reliability in Modern Power Systems. *International Journal of Research Publications in Engineering, Technology and Management (IJRPETM)*, 5(4), 7106-7110.
48. Poornima, G., & Anand, L. (2024, April). Effective Machine Learning Methods for the Detection of Pulmonary Carcinoma. In *2024 Ninth International Conference on Science Technology Engineering and Mathematics (ICONSTEM)* (pp. 1-7). IEEE.
- Garg, V. K., Soundappan, S. J., & Kaur, E. M. (2020). Enhancement in intrusion detection system for WLAN using genetic algorithms. *South Asian Research Journal of Engineering and Technology*, 2(6), 62-64.
49. Rengarajan, A., Jayakumar, C., & Sugumar, R. (2012). Optimization Of Recent Attacks Using Internet Protocol. *National Journal of System and Information Technology*, 5(1), 8.
50. Mathew, A. (2024). AI TRiSM: Trust, Risk, and Security Management in Cybersecurity. *Cybersecurity*, 4(3), 84-90.
51. Mathew, A. (2025). Deep seek vs. ChatGPT: A deep dive into AI Language mastery. *Int J Multidisciplinary Res*, 7(1), 1-5.